

High Yield Series

640W Grow Light

4' x 4'



L x W x H = 47.5" x 48.5" x 2.5"

Description

Carson's 640W full spectrum LED grow light uses white, red, and UV light technology. Hanging from rope ratchet hangers, the 640W twin-tube system replaces a 1000W double ended high pressure sodium bulb and covers a 5' x 5' grow tent. Ideal for vertical farming as the light source can be twelve inches or less away from the canopy when in veg and within inches away from the canopy during flower.

Key Features

- Uses private label SMD LED chips
- Rated for 50,000 hours
- 5 year warranty
- IP rating: IP65
- Input voltage: AC 110V-277V
- Amps: 5.33 @ 120V, 2.67 @ 240V, 2.31 @ 277V
- Daisy chain allows flexibility to add or remove beams
- Customized drivers are tailored to fit on each beam
- Efficiency: 1.7 umol/J
- PPF: 1088 umol/s
- Weight = 29 lbs
- LED quantity: 800 chips
- Annual Savings of \$331.13

Calculations are based on 6,570 annual hours of operation and \$0.14 average cost per kWh

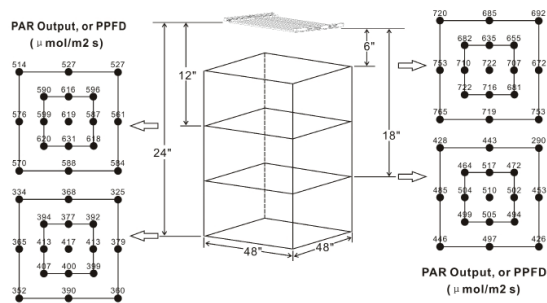
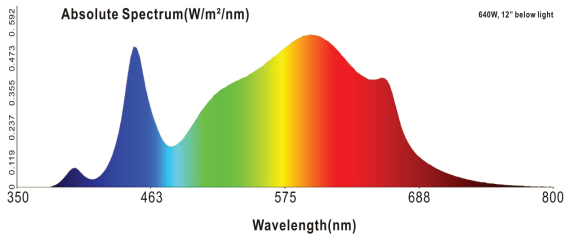

Ordering Information: CT-D02080GLB-8x4

CT	D	02	080	G	L	B	8x4
Line	Chip	Dimmable	Watts	Series	Type	Color	# of Beams
CT - Premium	D - DC	02 - 0-10V Dimmable	080 - 80 Watts	G - Grow	L - Light	B - White	4x4 - 4 Beams 5x4 - 5 Beams 6x4 - 6 Beams 7x4 - 7 Beams 8x4 - 8 Beams 9x4 - 9 Beams